ArduCAM

ArduCAM Camera Shield V2

Data Sheet

Rev 1.0, Oct 2016

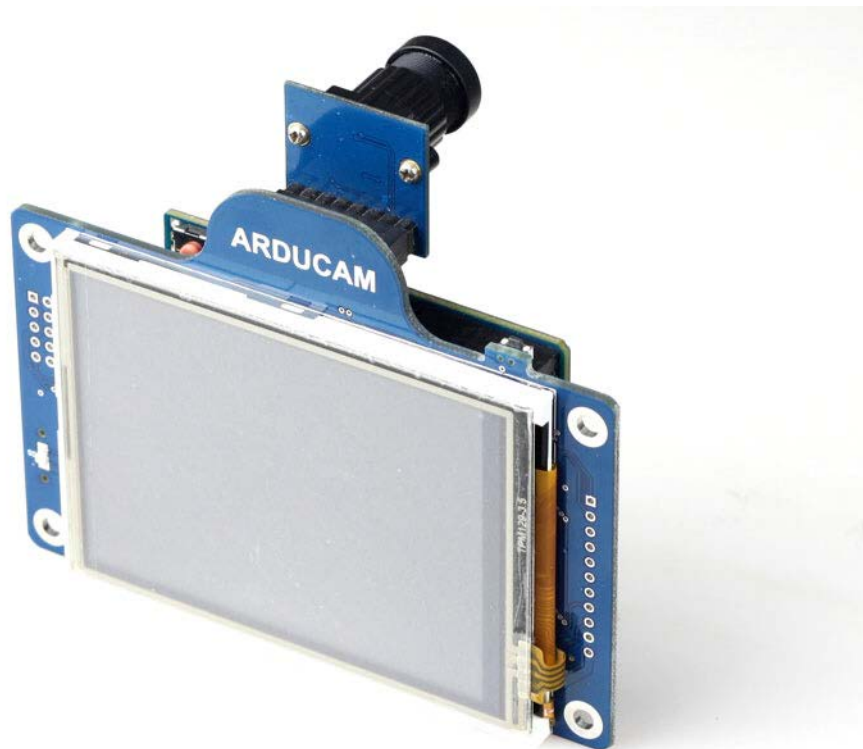

Table of Contents

1 Introduction 2

2 Application..... 3

3 Features..... 3

4 Key Specifications 4

5 Pin Definition..... 4

6 Block Diagram..... 6

7 Functions..... 6

7.1 Single Capture Mode 6

7.2 Multiple Capture Mode 6

7.3 JPEG Compression 6

7.4 Normal Read and Burst Read Operation 6

7.5 Rewind Read Operation 6

7.6 Low Power Mode..... 7

7.7 Image Sensor Control 7

8 Mechanical Dimension..... 8

9 Order Information 8

1 Introduction

ArduCAM series camera shield is a universal camera control board for Arduino. It hides the complex nature of the camera and provides the plug and play camera control interface as well as the ready to use software source code library and demo code. User can make it works in minutes without writing a line of code. The ArduCAM supports variety camera modules from 0.3MP to 5MP with different format like RAW, RGB, YUV, JPEG and can be well mated with standard Arduino boards.

ArduCAM V2 is the second generation of ArduCAM shields, it offers the improved performance and enhanced functions than the previous revisions. It can not only capture decent 5MP JPEG images, but also can do 5MP full resolution RAW image capture, which makes it to be the ideal solution for IoT and scientific image processing applications. Even more it can record short movie clips as well.

The ArduCAM is straightforward enough that it can be easily used with an Arduino, however this simple interface means that the ArduCAM is equally easily integrated with other single board computers such as the Raspberry Pi and the Beaglebone black. It isn't just a camera for the Arduino, it's a camera that because it can be easily interfaced to an Arduino, can be easily interfaced to any single board computer, either directly, or through an Arduino if needed for a larger system without exposed SPI/I2C busses. In short, the ArduCAM brings a plug and play solution to digital cameras at the hardware level.

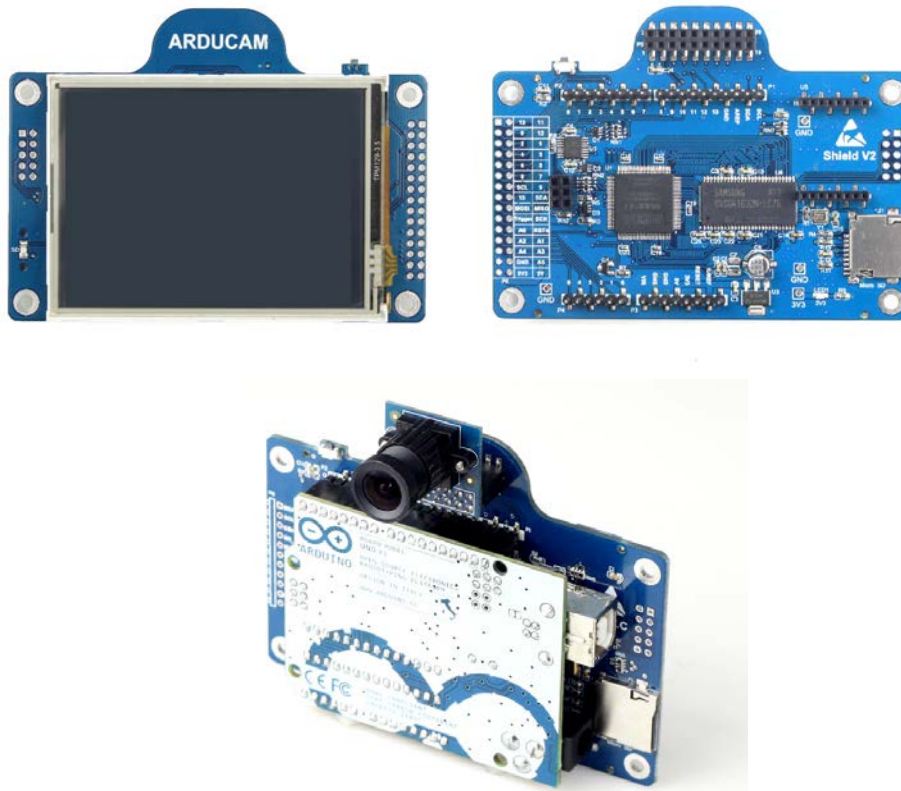

Figure 1 ArduCAM Shield V2

2 Application

- IoT cameras
- Robot cameras
- Wildlife cameras
- Scientific cameras
- Machine vision
- Other battery-powered products
- Can be used with any MCU, Raspberry Pi, ARM, DSP, FPGA platforms

3 Features

- Support 0.3MP~5MP camera modules, see Table 1
- 3.2 inch TFT LCD with touch screen
- Build in SD/TF card socket
- Support JPEG compression mode, single and multiple shoot mode, one time capture multiple read operation, burst read operation, low power mode and etc.
- Support almost any microcontroller platform, see Table 2
- Provide open source code library, please visit [github.org/arducam](https://github.com/arducam)
- All ArduCAM's IO ports are 5V/3.3V tolerant
- Well mated with standard Arduino boards

Table 1 Supported Camera Modules

Resolution	Sensor Vendor	Camera Module	Manufacture
0.3MP	Omnivision	OV7660 / OV7670 / OV7675 / OV7725	ArduCAM
0.3MP	Aptina	MT9V111	ArduCAM
1.3MP	Aptina	MT9M112 / MT9M001	ArduCAM
2MP	Omnivision	OV2640	ArduCAM
2MP	Aptina	MT9D111 / MT9D112	ArduCAM
3MP	Omnivision	OV3640	ArduCAM
3MP	Aptina	MT9T112	ArduCAM
5MP	Omnivision	OV5640 / OV5642	ArduCAM

Table 2 Supported Hardware Platforms

Platform	Type	Manufacture
8bit MCU	Arduino UNO / MEGA / DUE / YUN	Arduino
Cortex-M3	Arduino DUE	Arduino
Cortex-M3	STM32 Develop Board	ArduCAM
ARM	Raspberry Pi B+ / Pi 2 / Pi 3	Raspberry Pi
ARM	BeagleBone Black	BeagleBone
MIPS	ArduCAM Nano ESP8266	ArduCAM

4 Key Specifications

- Power supply 5V/50mA
Not including Camera Module
- SPI speed: 8MHz
- Frame buffer: 8MByte
- Format support: RAW, YUV, RGB, JPEG
- Weight: 50g
- 3.2" TFT LCD with touch screen
- SD/TF card socket
- Resolution support:
0.3MP ~ 5MP
- Size: 99 x 59 mm
- Temperature: -10°C ~ +55°C

5 Pin Definition

Figure 2 shows the pin out diagram for ArduCAM shield V2. There are four connectors on ArduCAM shield. One is standard ArduCAM connector which can well mate with Arduino board, the pin definition see Table 3. The second connector P6 is an alternative port for Arduino pins, some of them are used by ArduCAM shield, the others are free pins, the pin definition see Table 4. The third connector is for camera module, the pin definition see Table 5. The fourth connector U5 is for ArduCAM Nano ESP8266 module extension, the pin definition see Table 6.

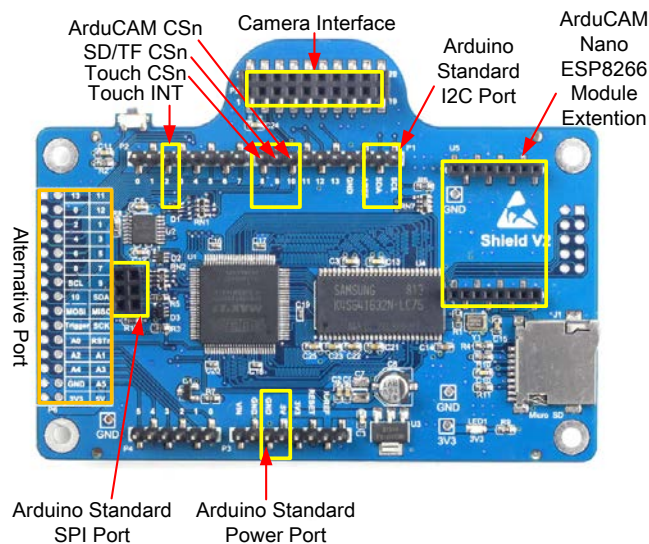

Figure 2 Pin Out Diagram

Table 3 ArduCAM Shield V2 Pin Definition

PIN NAME	TYPE	Location (Arduino standard)	DESCRIPTION
CS	Input	10	SPI slave chip select input
MOSI	Input	ICSP-MOSI	SPI master output slave input
MISO	Output	ICSP-MISO	SPI master input slave output
SCLK	Input	ICSP-SCLK	SPI serial clock
SDA	Bi-directional	Arduino standard	Two-Wire Serial Interface Data I/O
SCL	Input	Arduino standard	Two-Wire Serial Interface Clock
Touch CS	Input	8	Touch screen chip select input
Touch INT	Output	2	Touch screen interrupt output
SD/TF CS	Input	9	SD/TF card chip select input

Table 4 Alternative P6 Pin Definition

PIN	NAME (Arduino standard)	PIN	NAME (Arduino standard)
1	13	2	11
3	0	4	12
5	2	6	1
7	4	8	3
9	6	10	5
11	8	12	7
13	SCL	14	9
15	10	16	SDA
17	MOSI	18	MISO
19	Trigger	20	SCK
21	A0	22	RSTn
23	A2	24	A1
25	A4	26	A3
27	GND	28	A5
29	3.3V	30	5V

Table 5 Camera Interface Pin Definition

PIN	NAME	PIN	NAME
1	3.3V	2	GND
3	SCL	4	SDA
5	VSYNC	6	HREF
7	PCLK	8	XCLK
9	D7	10	D6
11	D5	12	D4
13	D3	14	D2
15	D1	16	D0
17	NC	18	NC
19	NC	20	NC

Table 6 ArduCAM Nano ESP8266 Module Interface Pin Definition

PIN	NAME	PIN	NAME
1	RST_n	2	GPIO01 (TXD)
3	A0	4	GPIO03 (RXD)
5	GPIO16 (CAM_CS)	6	GPIO05 (SCL)
7	GPIO14 (SPI_SCK)	8	GPIO04 (SDA)
9	GPIO12 (SPI_MISO)	10	GPIO00 (SD_CS)
11	GPIO13 (SPI_MOSI)	12	GPIO02 (TS_CS)
13	3.3V	14	GPIO15
15	5V	16	GND

6 Block Diagram

Figure 3 shows the block diagram of ArduCAM shield which is composed by the camera module, LCD screen and an ArduChip. The camera module is changeable. The ArduChip uses ArduCAM proprietary third generation camera controller technology which handles the complex camera, memory, LCD and user interface hardware timing and provides a user friendly SPI interface.

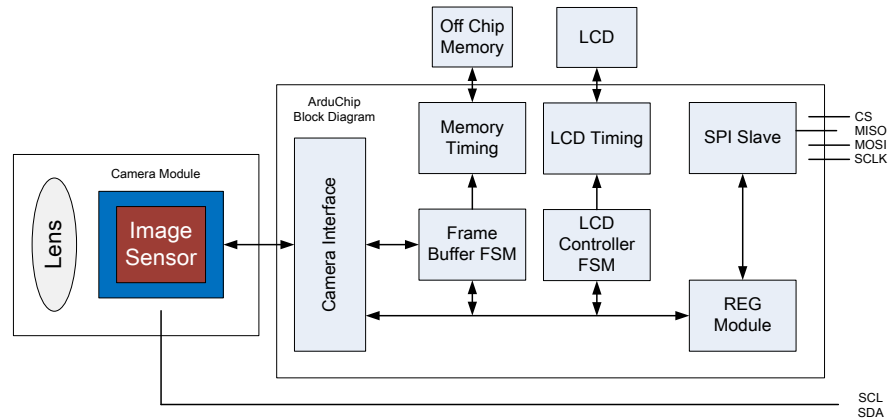

Figure 3 ArduCAM Shield Block Diagram

7 Functions

7.1 Single Capture Mode

Single capture mode is the default capture mode of the camera. After issuing a capture command via SPI port, the ArduCAM will wait for a new frame and buffer the one entire image data to the frame buffer, and then assert the completion flag bit in the register. User only needs to poll the flag bit from the register to check out if the capture is done.

7.2 Multiple Capture Mode

Multiple capture mode is advanced capture mode. By setting the number of frames in the capture register, the ArduCAM will capture consequent frames after issuing capture command.

7.3 Short Movie Recording Mode

Short movie recording mode is advanced capture mode. By setting the maximum number of frames in the corresponding register, the ArduCAM will capture continuous frames until the 8MByte frame buffer is full.

7.4 JPEG Compression

The JPEG compression function is implemented in the image sensor. With proper register settings to the sensor, user can get different resolution with JPEG image stream output.

7.5 Normal Read and Burst Read Operation

Normal read operation reads each image data by sending a read command in one SPI read operation cycle. While burst read operation only need to send a read command then read multiple image data in one SPI read operation cycle. It is recommended to use burst read operation to get better throughput performance.

7.6 Rewind Read Operation

Sometimes user wants to read the same frame of image data multiple times for processing, the rewind read operation is designed for this purpose. By resetting the read pointer to the

beginning of the image data, user can read the same image data from the start point again.

7.7 Low Power Mode

Some battery power device need save power when in the idle status, the ArduCAM offers the low power mode to reduce power consumption, by shutdown the sensor and memory circuits.

7.8 Image Sensor Control

Image sensor control function is implemented in the image sensor. By setting proper set of register settings, user can control the exposure, white balance, brightness, contrast, color saturation and etc.

More technical information about ArduCAM shield, please read ArduCAM hardware and software Application Note for detail.

8 Mechanical Dimension

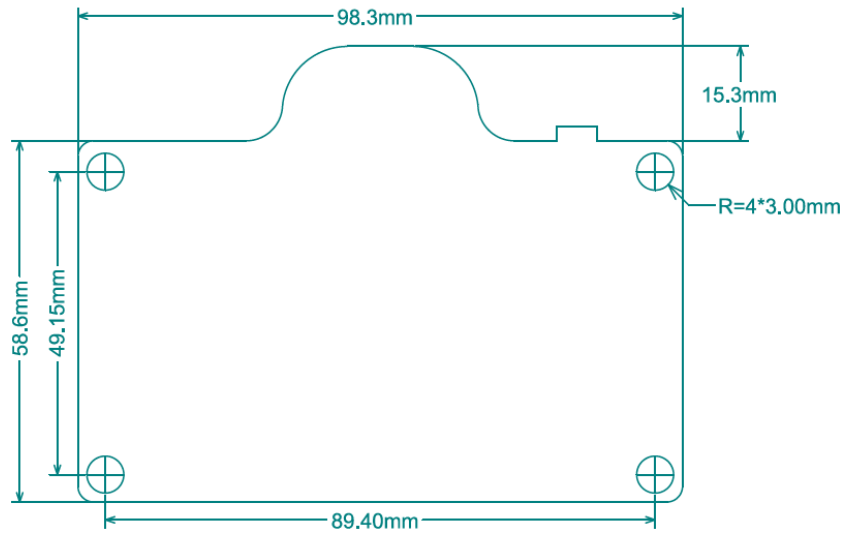

Figure 3 ArduCAM Mechanical Dimension

9 Order Information

Part Number	Description
ArduCAM-LF Shield V2	ArduCAM shield with LCD screen
ArduCAM-F Shield V2	ArduCAM shield without LCD screen