



# ArduCAM-Mini-5MP-Plus OV5642 Camera Module

5MP SPI Camera User Guide

Rev 1.0, Oct 2016



**Table of Contents**

1 Introduction .....2

2 Application.....2

3 Features.....3

4 Key Specifications .....3

5 Pin Definition.....3

6 Block Diagram.....4

7 Functions.....4

7.1 Single Capture Mode .....4

7.2 Multiple Capture Mode .....4

7.3 Short Movie Capture Mode.....4

7.4 Eternal Hardware Trigger.....5

7.5 JPEG Compression .....5

7.6 Normal Read and Burst Read Operation .....5

7.7 Rewind Read Operation .....5

7.8 Low Power Mode.....5

7.9 Image Sensor Control .....5

8 Mechanical Dimension.....6

# 1 Introduction

ArduCAM-Mini-5MP-Plus(OV5642) is performance improved version compared to its predecessor ArduCAM-M-5MP. It is a general purpose high definition 5MP SPI camera, which reduce the complexity of the camera control interface. It integrates 5MP CMOS image sensor OV5642, and provides miniature size, as well as the easy to use hardware interface and open source code library. The ArduCAM mini can be used in any platforms like Arduino, Raspberry Pi, ESP8266, Maple, Chipkit, Beaglebone black, as long as they have SPI and I2C interface and can be well mated with standard Arduino boards. ArduCAM mini not only offers the capability to add a camera interface which doesn't have in some low cost microcontrollers, but also provides the capability to add multiple cameras to a single microcontroller.

ArduCAM-Mini-5MP-Plus is the second generation of ArduCAM module, it offers the improved performance and enhanced functions than the previous revisions. It can not only capture decent 5MP JPEG images, but also can do 5MP full resolution RAW image capture, which makes it to be the ideal solution for IoT and scientific image processing applications. Even more it can record short movie clips as well.

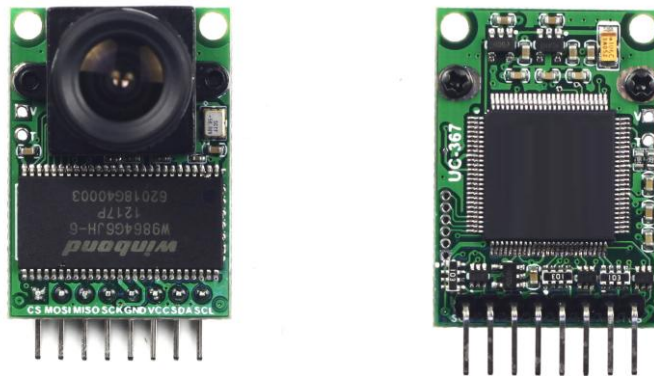

Figure 1 ArduCAM Mini 5MP Plus

# 2 Application

- IoT cameras
- Robot cameras
- Wildlife cameras
- HDR camera
- Other battery-powered products
- Can be used in MCU, Raspberry Pi, ARM, DSP, FPGA platforms

### 3 Features

- 5MP image sensor OV5642
- M12/CS mount replaceable lens
- I2C interface for the sensor configuration
- SPI interface for camera commands and data stream
- Support external hardware trigger input
- Support JPEG compression mode, single and multiple shoot mode, short movie recording, one time capture multiple read operation, burst read operation, low power mode and etc.
- All IO ports are 5V/3.3V tolerant
- Well mated with standard Arduino boards
- Provide open source code library for Arduino, ESP8266, Raspberry Pi, etc
- Small form of factor

### 4 Key Specifications

- Power supply 3.3V~5V
- SPI speed: Max 8MHz
- Frame buffer: 8MByte
- Default M12 Lens: 90°
- Size: 34 x 24 mm
- Weight: 20g
- Temperature: -10°C ~+55°C
- Active array size: 2592x1944
- Shutter: rolling shutter
- Pixel Size: 1.4 μm x 1.4 μm
- Resolution support: 5MP, 1080p, 720p, VGA, QVGA
- Format support: RAW, YUV, RGB, JPEG

### 5 Pin Definition

Table 1 ArduCAM-Mini-5MP Pin Definition

Pin No.	PIN NAME	TYPE	DESCRIPTION
1	CS	Input	SPI slave chip select input
2	MOSI	Input	SPI master output slave input
3	MISO	Output	SPI master input slave output
4	SCLK	Input	SPI serial clock
5	GND	Ground	Power ground
6	VCC	POWER	3.3V~5V Power supply
7	SDA	Bi-directional	Two-Wire Serial Interface Data I/O
8	SCL	Input	Two-Wire Serial Interface Clock

## 6 Block Diagram

Figure 2 shows the block diagram of ArduCAM mini shield which is composed by lens, image sensor and an ArduChip. The image sensor is 5MP CMOS OV5642 from Omnivision. The ArduChip uses ArduCAM proprietary third generation camera controller technology which handles the complex camera, memory and user interface hardware timing and provides a user friendly SPI interface.

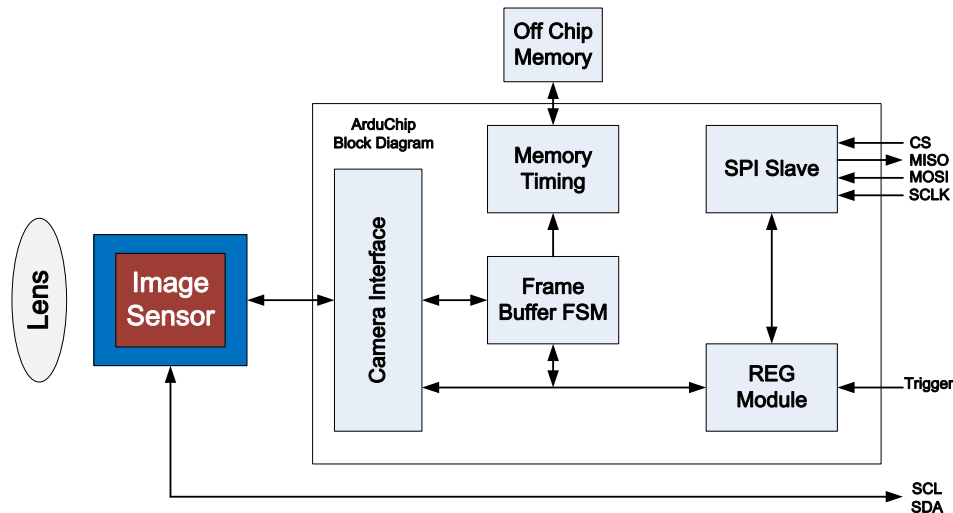

Figure 2 ArduCAM Mini Shield Block Diagram

## 7 Functions

### 7.1 Single Capture Mode

Single capture mode is the default capture mode of the camera. After issuing a capture command via SPI port, the ArduCAM will wait for a new frame and buffer the one entire image data to the frame buffer, and then assert the completion flag bit in the register. User only needs to poll the flag bit from the register to check out if the capture is done.

### 7.2 Multiple Capture Mode

Multiple capture mode is advanced capture mode. By setting the number of frames in the capture register, the ArduCAM will capture consequent frames after issuing capture command. Note that number of frames should be set properly and make sure do not exceed the maximum memory space. Multi capture mode can be use to take the same scene with different exposure to create HDR images.

### 7.3 Short Movie Capture Mode

Short movie capture mode is the continuous capture mode until the 8MByte frame is full. User can use this mode record couple of seconds video and save to AVI file into SD card.

#### 7.4 Eternal Hardware Trigger

External hardware trigger input (Active High) can be used to start a capture manually, software part only needs to polling the "capture done" status bit before reading the image data. Figure 3 shows the hardware pins for trigger.

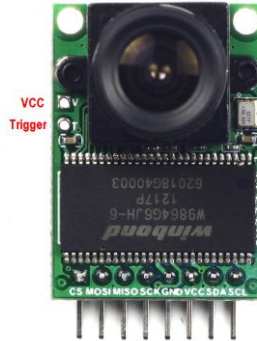

Figure 2 Hardware Trigger Pins

#### 7.5 JPEG Compression

The JPEG compression function is implemented in the image sensor. With proper register settings to the sensor, user can get different resolution with JPEG image stream output. It is recommended to use JPEG output to get higher resolution than RGB mode, due to the limitation of frame buffer.

#### 7.6 Normal Read and Burst Read Operation

Normal read operation reads each image data by sending a read command in one SPI read operation cycle. While burst read operation only need to send a read command then read multiple image data in one SPI read operation cycle. It is recommended to use burst read operation to get better throughput performance.

#### 7.7 Rewind Read Operation

Sometimes user wants to read the same frame of image data multiple times for processing, the rewind read operation is designed for this purpose. By resetting the read pointer to the beginning of the image data, user can read the same image data from the start point again.

#### 7.8 Low Power Mode

Some battery power device need save power when in the idle status, the ArduCAM offers the low power mode to reduce power consumption, by shutdown the sensor circuits.

#### 7.9 Image Sensor Control

Image sensor control function is implemented in the image sensor. By setting proper set of register settings, user can control the exposure, white balance, brightness, contrast, color saturation and etc.

More technical information about ArduCAM mini shield, please read ArduCAM-Mini-5MP-Plus Hardware Application Note.pdf and ArduCAM Software Application Note.pdf for detail.

## 8 Mechanical Dimension

